

General Description

The TD8201 is a step-up DC/DC converter designed for driving up to 5 white LEDs in series from a single cell Lithium Ion battery with constant current. Because it directly regulates output current, the TD8201 is ideal for driving light emitting diodes (LEDs) whose light intensity is proportional to the current passing through them, not the voltage across their terminals. A single external resistor sets LED current between 2mA and 20mA, which can then be easily adjusted using either a DC voltage or a pulse width modulated (PWM) signal up to 100KHz. Its low 104mV feedback voltage reduces power loss and improves efficiency. The OV pin monitors the output voltage and turns off the converter if an over-voltage condition is present due to an open circuit condition. The TD8201 is available in SOT23-6 packages.

Features

- Drives Up to 5 Series White LEDs from 3V
- Up to 87% Efficiency
- 1.25MHz Fixed Switching Frequency
- Low 104mV Feedback Voltage
- Open Load Shutdown
- PWM Dimming
- SOT23-6 Packages
- RoHS compliant

Applications

- Cell Phones
- Handheld Computers and PDAs
- Digital Cameras
- Small LCD Displays

Pin Assignments

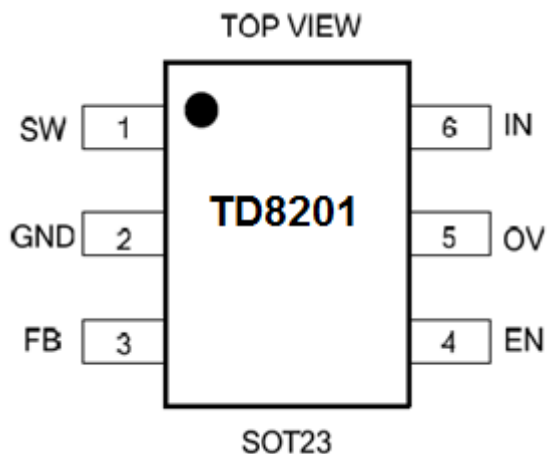

Pin Description

Pin Number	Pin Name	Description
1	SW	Power Switch Output. Connect the inductor and the blocking Schottky diode to SW.
2	GND	Ground
3	FB	Feedback input pin. The reference voltage at this pin is 104mV. Connect the cathode of the lowest LED to FB and a current sense resistor between FB and GND.
4	EN	Enable pin. A high input at EN enables the device and a low input disables the devices. When not used, connect EN to the input source for automatic startup.
5	OV	Over Voltage Input. OV measures the output voltage for open circuit protection. Connect OV to the output at the top of the LED string.
6	IN	Input Supply Pin. Must be locally bypassed.

Ordering Information

TD8201 □ □

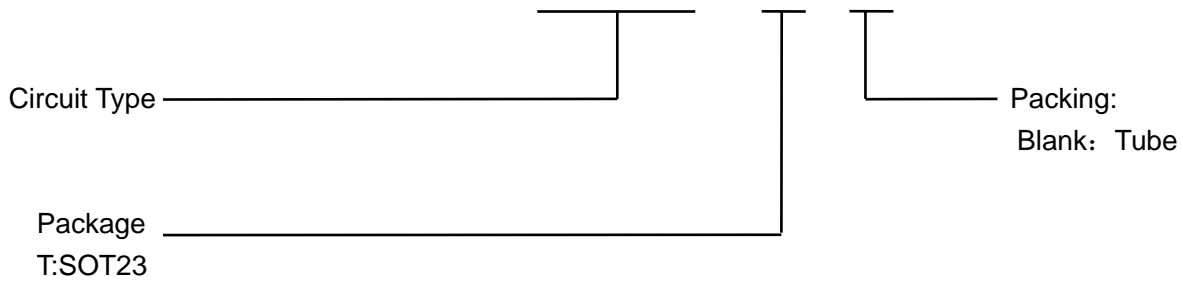

Functional Block Diagram

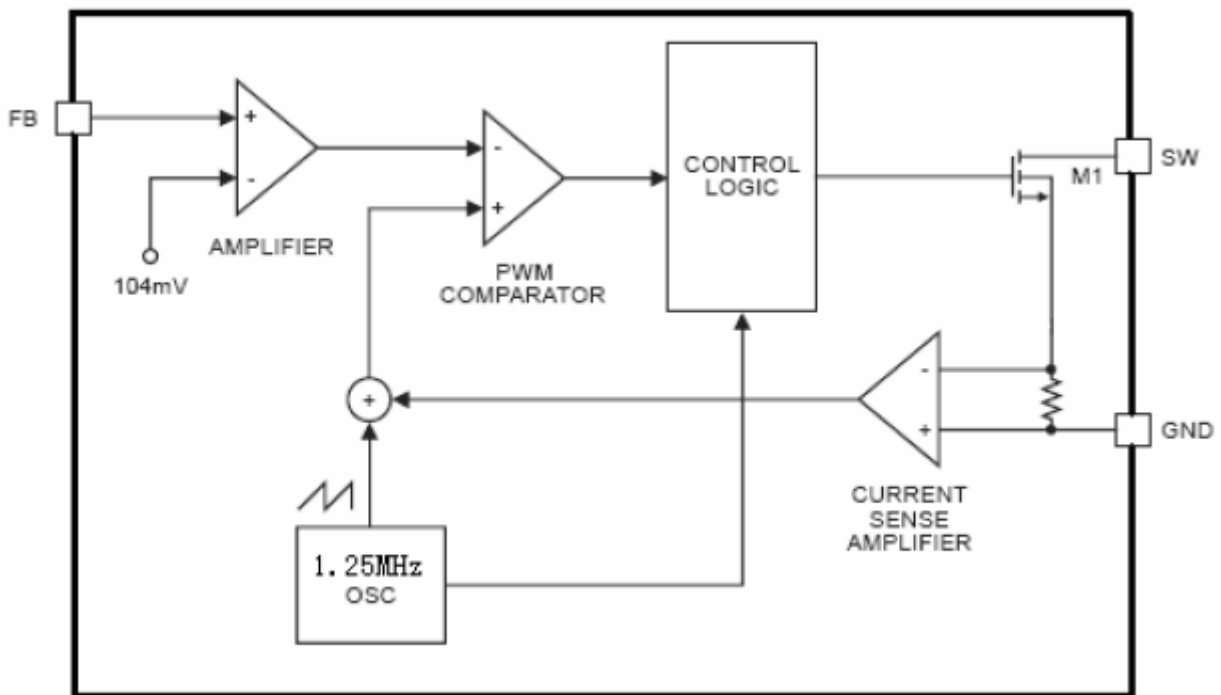

Functional Block Diagram of TD8201

Absolute Maximum Ratings

Symbol	Parameter	Rating	Unit
V _{IN}	Input Voltage	-0.3 ~ 6	V
V _{SW}	Voltage at SW Pin	-0.5 ~ 25	V
V _{IO}	All Other I/O Pins	GND-0.3 to VDD+0.3	V
P _D MAX	Power Dissipation (Note 2)	Internally Limited	W
P _{TR1}	Thermal Resistance, SOT-23-6, θ_{JA}	220	°C/W
T _{stg}	Storage Temperature	-55 to 150	°C
T _{solder}	Package Lead Soldering Temperature	260 °C, 10s	
	ESD Susceptibility (Note 3)	3	kV

Recommended Operating Conditions

Symbol	Parameter	Range	Unit
V _{IN}	V _{IN} Supply Voltage	3 to 5.5	V
V _{SW}	Output Voltage	V _{IN} to 20	V
T _{OPT}	Operating Temperature	-40 to +85	°C

Electrical Characteristics

The following specifications apply for $V_{IN} = V_{EN} = 3.6V$ $T_A = 25^\circ C$, unless specified otherwise.

Symbol	Parameter	Test Conditions	TD8201			Unit
			Min.	Typ.	Max.	
VIN	Input Voltage		3.0		5.5	V
VFB	FB Pin Voltage	Driving 4xLED@20mA	94	104	114	mV
Isw	SW Pin leakage Current	$V_{EN} = 0, V_{SW} = 20V$			1	μA
Ioff	Operating Current (Shutdown)			0.1	1	μA
Isby	Operating Current (Quiescent)	$V_{FB} = 0.5V$		100	350	μA
Fsw	Switching Frequency		1.0	1.25	1.5	MHz
Dmax	Maximum Duty Cycle	$V_{FB} = 0V$	85	90		%
VEN_H	EN Minimum High Level		1.5			V
VEN_L	EN Maximum Low Level				0.4	V
RON	SW On Resistance			1.4		Ω
ILIMIT	SW Current Limit			400		mA
VOV	Open Circuit Shutdown Threshold	VOV Rising		20		V
VIN	Input Voltage		3.0		5.5	V

Typical Operating Characteristics

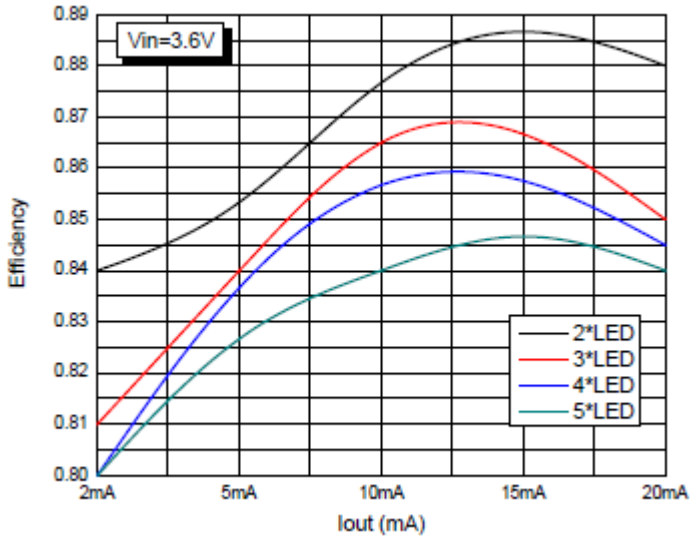

Efficiency vs Number of LEDs

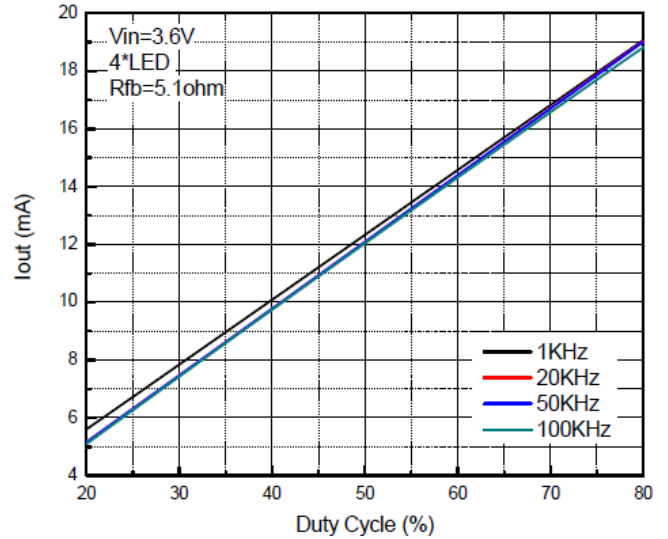

Dimming Control using PWM signal to EN pin

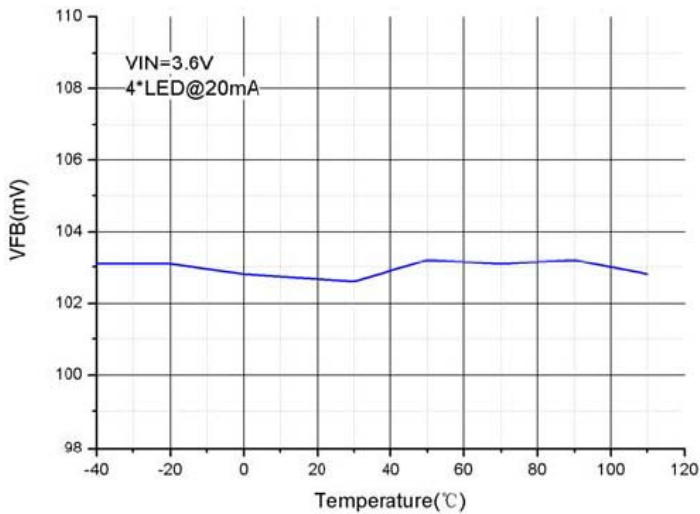

VFB VS Temperature

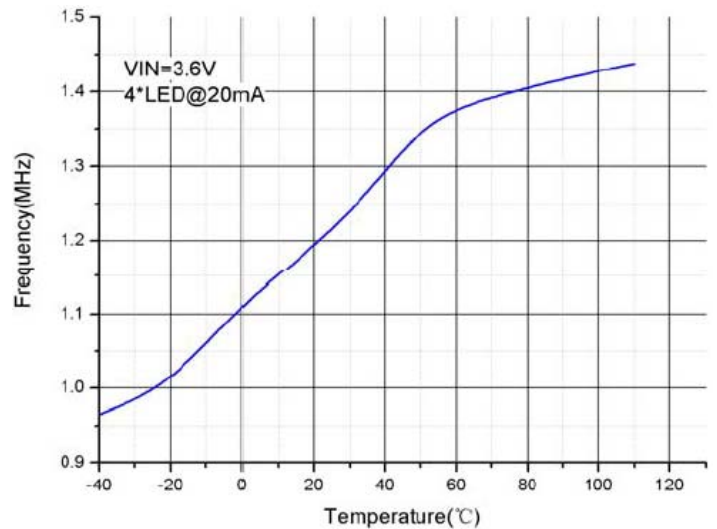

Frequency VS Temperature

Typical Application Circuit

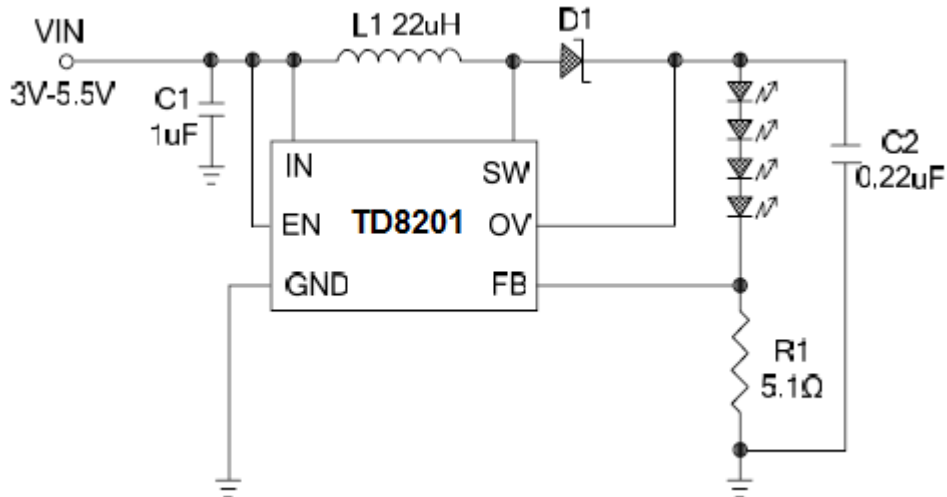

OPERATION DESCRIPTION

The TD8201 uses a constant frequency, peak current mode boost regulator architecture to regulate the series string of white LEDs. The operation of the TD8201 can be understood by referring to the simplified block diagram shown above. At the start of each oscillator cycle, the control logic turns on the power switch M1. The signal at the non-inverting input of the PWM comparator is proportional to the switch current, summed together with a portion of the oscillator ramp. When this signal reaches the level set by the output of error amplifier, the PWM comparator resets the latch in the control logic and turns off the power switch. In this manner, error amplifier sets the correct peak current level to keep the LED current in regulation. If the feedback voltage starts to drop, the output of the error amplifier increases. This results in more current to flow through M1, hence increasing the power delivered to the output.

Function Description

Driving Capability

V _{in}	I _{LED} =15mA	I _{LED} =20mA
3V	5 x LED	4 x LED
3.6V	5 x LED	5 x LED
5V	5 x LED	5 x LED

Inductor Selections

PARTNUMBER	DCR (Ω)	CURRENT RATING (mA)	MANUFACTURER
LQH3C220	0.71	250	MURATA
CDRH3D16-220	0.53	350	SUMIDA
LB2012B220M	1.7	75	TAIYO YUDEN
LEM2520-220	5.5	125	TAIYO YUDEN
EJPC220KF	4.0	160	PANASONIC

Capacitor Selection

The small size of ceramic capacitors makes them ideal for TD8201 applications. X5R and X7R types are recommended because they retain their capacitance over wider voltage and temperature ranges than other types such as Y5V or Z5U. A 1 μ F input capacitor and a 0.22 μ F output capacitor are sufficient for most TD8201 applications.

Diodes Selection

Schottky diodes, with their low forward voltage drop and fast reverse recovery, are the ideal choices for TD8201 applications. The forward voltage drop of a Schottky diode represents the conduction losses in the diode, while the diode capacitance (C_T or C_D) represents the switching losses. For diode selection, both forward voltage drop and diode capacitance need to be considered. Schottky diodes with higher current ratings usually have lower forward voltage drop and larger diode capacitance, which can cause significant switching losses at the 1.25MHz switching

frequency of the TD8201. A Schottky diode rated at 100mA to 200mA is sufficient for most TD8201 applications. Some recommended Schottky diodes are listed in the following table:

PART NUMBER	FORWARD CURRENT (mA)	VOLTAGE DROP (V)	DIODE CAPACITANCE	MANUFACTURER
CMDSH-3	100	0.58@100mA	7.0@10V	Central
CMDSH2-3	200	0.49@200mA	15@10v	Central
BAT54	200	0.53@100mA	10@25v	Zetex

LED Current Control

The LED current is controlled by the feedback resistor. The feedback reference is 104mV. The LED current is 104mV/R_{fb}. In order to have accurate LED current, precision resistors are preferred (1% is recommended). The formula and table for R_{FB} selection are shown below

$$R_{FB} = 104mV/I_{LED}$$

I _{LED} (mA)	R _{FB} Value (Ω)
5	20.8
10	10.4
15	6.93
20	5.1

Open Circuit Protection

Open circuit protection will shut off the TD8201 if the output voltage goes too high when the OV pin is tied to the output. In some cases an LED may fail, which will result in the feedback voltage always being zero. The TD8201 will then switch at its maximum duty cycle boosting the output voltage higher and higher. By connecting the OV pin to the top of the LED string the TD8201 checks this condition and if the output ever exceeds 20V, the TD8201 will shut down. The part will not switch again until the power is recycled.

Function Description(Cont.)

Dimming Control

There are three different types of dimming control circuits:

1. Using a DC Voltage

For some applications, the preferred method of brightness control is a variable DC voltage to adjust the LED current. The dimming control using a DC voltage is shown in Figure 3. As the DC voltage increases, the voltage drop on R2 increases and the voltage drop on R1 decreases. Thus, the LED current decreases. The selection of R2 and R3 will make the current from the variable DC source much smaller than the LED current and much larger than the FB pin bias

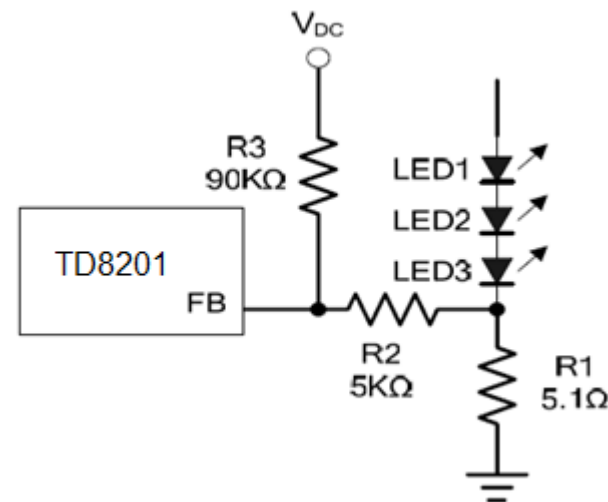

2. Using a PWM Signal to EN Pin

With the PWM signal applied to the EN pin, the TD8201 is turned on or off by the PWM signal. The LEDs operate at either zero or full current. The average LED current increases proportionally with the duty cycle of the PWM signal. A 0% duty cycle corresponds to zero LED current. A 100% duty cycle corresponds to full current. The frequency range of the PWM signal should be up to 100KHz

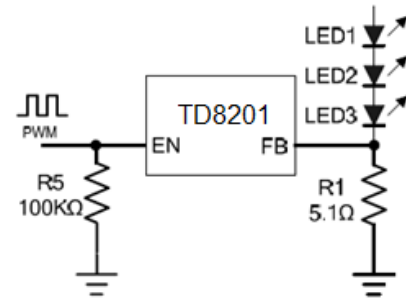

3. Using a Filtered PWM Signal

The filtered PWM signal can be considered as an adjustable DC voltage. It can be used to replace the variable DC voltage source in dimming control.

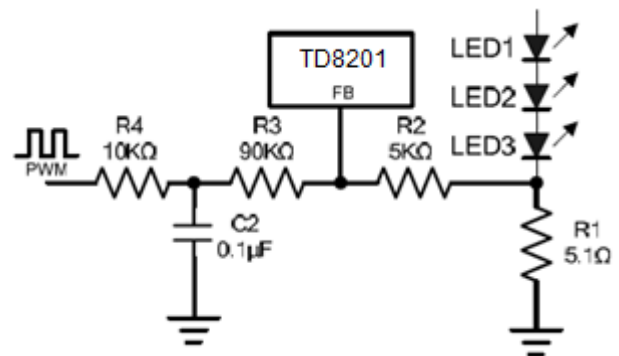

Board Layout Consideration

As with all switching regulators, careful attention must be paid to the PCB board layout and component placement. To maximize efficiency, switch rise and fall times are made as short as possible. To prevent electromagnetic interference (EMI) problems, proper layout of the high frequency switching path is essential. The voltage signal of the SW pin has sharp rise and fall edges. Minimize the length and area of all traces connected to the SW pin and always use a ground plane under the switching regulator to minimize interplane coupling. In addition, the ground connection for the feedback resistor R1 should be tied directly to the GND pin and not shared with any other component, ensuring a clean, noise-free connection.

Package Information

SOT23-6

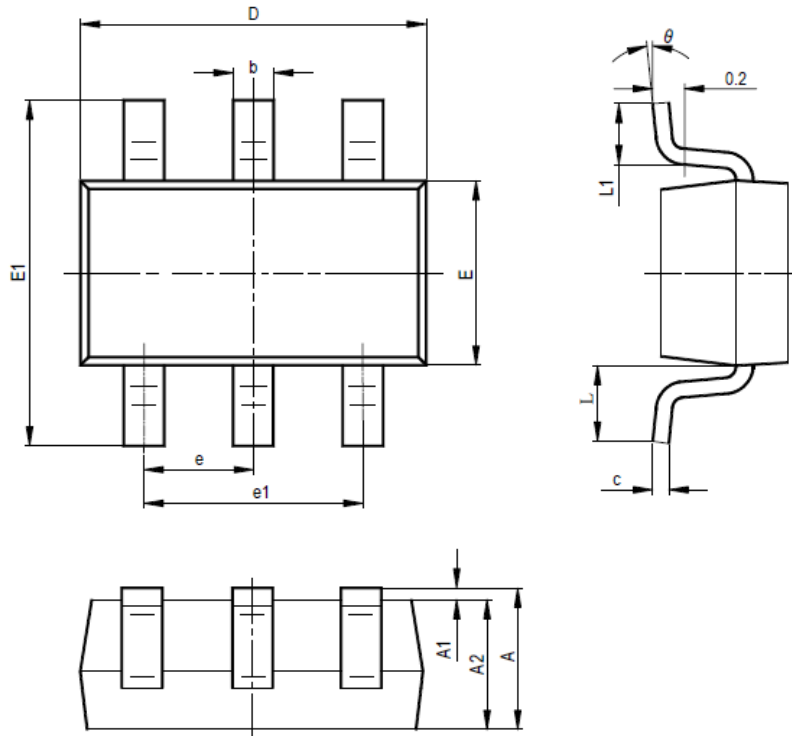

SYMBOL	MILLIMETERS		INCHES	
	MIN	MAX	MIN	MAX
A	1.050	1.250	0.041	0.049
A1	0.000	0.100	0.000	0.004
A2	1.050	1.150	0.041	0.045
b	0.300	0.400	0.012	0.016
c	0.100	0.200	0.004	0.008
D	2.820	3.020	0.111	0.119
E	1.500	1.700	0.059	0.067
E1	2.650	2.950	0.104	0.116
e	0.950TYP		0.037TYP	
e1	1.800	2.000	0.071	0.079
L	0.700REF		0.028REF	
L1	0.300	0.600	0.012	0.024
θ	0°	8°	0°	8°

Design Notes